

Instructional  
Manual



**BAM**  
BOMBER  
AEROSPACE  
MATERIAL



**MONSTER** RIPLE

**bomber**

MARZOCCHI SINCE 1949 MARZOCCHI SINCE 1949 MARZOCCHI SINCE 1949



INDEX	Page
OWNER'S INFORMATION .....	2
GENERAL SPECIFICATIONS .....	3
SPECIFIC MARZOCCHI TOOLS .....	3
GENERAL RULES FOR A CORRECT OVERHAULING AND MAINTENANCE .....	4
FAILURES, CAUSES AND REMEDIES .....	4
RECOMMENDATIONS FOR USE .....	4
INSTALLATION .....	4
MOUNTING THE FORK ON THE FRAME .....	5
FRONT WHEEL FIXING .....	6
DISC BRAKE SYSTEM ASSEMBLY .....	7
ADJUSTMENTS .....	7
DISASSEMBLY .....	8
DISASSEMBLY DIAGRAM .....	9
REASSEMBLY .....	12
FORK EXPLODED VIEW .....	16

The figures and descriptions in this pamphlet are provided as a guide.  
 We reserve the right to make changes to the products without notice in line with our policy of continuous improvement.

**Always respect Nature when riding !**

**OWNER'S INFORMATION**

**IMPORTANT:** Installing a Marzocchi suspension system is a very delicate operation that must be carried out with extreme care. These installation and maintenance instructions are designed for experienced bicycle mechanics and must be followed exactly as written and specified. Failure to precisely follow these instructions could cause damage to one or more components of the Marzocchi suspension system. This damage may not be readily visible or apparent and could lead to unexpected failure on one or more components of your suspension to such extent that the rider may loose control of the bicycle and suffer severe injury.

**The responsibility of the owner**

- 1) The Marzocchi suspension system is designed to absorb the shocks of an uneven road surface in order to give the rider more control over this bicycle. It is not designed to absorb the forces generated by jumps or other acrobatic maneuvers. If you subject the Marzocchi suspension system to repeated jumps or other acrobatic maneuvers, you could cause one or more of the components of the suspension system to unexpectedly break, resulting in a loss of bicycle control and serious injury to the rider.
- 2) Some of the parts of the bicycle, such as the brakes, steering, tires, wheel assembly and shifters may not have been adjusted at the time the Marzocchi suspension system was installed on the bicycle. Before you ride the bicycle, be sure all the parts of the bicycle were properly adjusted and functioning properly.
- 3) All of the components of the suspension system must be correctly assembled and tightened exactly to the specified torque values. Periodically check the torque of these components to insure that they are correct. Failure to properly assemble and tighten the components could cause one or more of the components to unexpectedly break, resulting in a loss of bicycle control and serious injury to the rider.
- 4) There are obvious risks associated with mountain biking and other types of bicycle riding. Despite the use of all safety equipment for the bicycle and the rider, either injuries or damages may occur. This is the responsibility of the rider. To reduce the risk of injury, all activities must be under proper supervision and only after proper training and experience. Good physical condition of the rider and the good state of the bicycle are essential to be a safe and successful rider.
- 5) Be sure to read and follow all the instructions and warnings which originally accompanied your bicycle. In addition, it is recommended for added safety and protection while riding that a good quality bicycle helmet be worn and that other safety devices such as lights, reflectors, or reflective clothing be used. Some cities and states may require the use of a helmet and other safety equipment. Follow all traffic rules and all other laws about safety equipment and use your bicycle where you are permitted to ride.
- 6) For any further information you might need, please call or write to this addresses:

**LARM**

Via Ca' dell'Orbo, 36 -  
 40055 Villanova di Castenaso (Bologna) - Italy  
 ☎ ++51/6053460 - Fax ++51/6053411

**MSC CORPORATION USA**

28231 Avenue Crocker - Unit 100  
 VALENCIA CA, 91355  
 ☎ +1 (805) 257-6630 - Fax +1 (805) 257-6636

**It is your responsibility to make sure the assembly instructions in this book are precisely followed.**

**Always ride safely and carefully.**

## GENERAL SPECIFICATIONS

- The double plate fork is specifically designed for Downhill use. Damped by two sealed hydraulic cartridges and sprung by a mechanical coil spring system.
- Stanchion tube secured to the crown and upper plate. The system gives the fork an unmatched structural strength.
- Parts subjected to friction are cooled and lubricated by specially formulated oil.
- Spring pre-load adjustment and rebound damping controlled via external top mount adjusters.
- Left slider comes with brake caliper support.
- Axle support of the motorbike type, with advanced pin and screw pin on both sides.
- Wheel pin (20 mm) available on request.

**Steer tube:** EASTON aluminum steer tubes available for 1 1/8" x267 mm, threadless

**Crown:** Forged and CNC-machined. T6-6082 aluminum alloy.

**Upper plate:** T6-6082 alloy. Two versions available for different frame sizes.

**Arch:** Forged and CNC-machined T6-6082 alloy.

**Stanchions:** Anodized EASTON aluminum with variable butting.

**Springs:** with variable pitch

**Sliders:** Cast and CNC-machined alloy

**Slider bushing:** composed of a copper base and impregnated with an anti-friction coating.

**Seals:** Computer designed oil seals guarantee the highest quality seals available.

**Oil:** Specially formulated oil which eliminates foaming and viscosity breakdown while providing complete stiction-free performance.

**Fork leg oil:** 380 cc, type EBH 16- SAE 7.5.

### This fork is supplied with:

- Warranty card
- Owner's manual
- Technical Specifications

### Size:

- travel: 175mm (6.9 inches)
- crown to axle length: 550.5 mm
- crown to upper plate length: 155.5 mm or 182.5 mm
- stanchions outer diameter: 40 mm
- fork leg distance between centers: 175 mm
- axle diameter: 20 mm / 17 mm

## SPECIFIC MARZOCCHI TOOLS

Ref.	Item./Art.	Description and use
A	536064GG	Slider protector: to remove the oil seal from the slider
B	R5083AC	Oil seal press: to press the oil seal into the slider

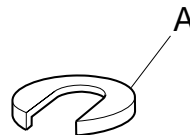
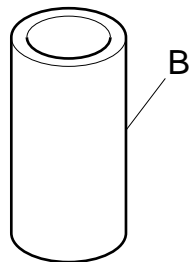

These are the specific tools necessary for an overhaul, you may find it necessary to use common tool found in your shop.



## GENERAL RULES

1. Where specified, assemble and disassemble the shock absorption system only using the LARM or MARZOCCHI special tools, as shown in the table.
2. On reassembling the suspension system, always use new seals.
3. If two screws are close one to the other, always tighten using a 1-2-1 sequence. In short, screw the first screw just up to the point it is well tightened, then tighten the second screw and then go back to the first one and screw it tighter.
4. Clean all metal parts with a special, preferably biodegradable solvent, such as trichloroethane or trichloroethylene.
5. Before reassembling, lubricate all parts in contact with each other using silicone fat spray.
6. Always grease the oil seal lips before reassembling.
7. Use wrenches with metric size only. Wrenches with inch size might damage the fastening devices even when their size is similar to that of the wrenches in metric size.

## FAILURES, CAUSES AND REMEDIES

This paragraph reports some troubles that may occur when using the fork. It also indicates possible causes and suggests a remedy. Always refer to this table before doing any repair work.

FAILURES	CAUSES	REMEDIES
Excessive oil build up on stanchions	1. Oil seal is worn out 2. Stanchion tube is scored 3. Excessive dirt on slider oil seal	1. Replace oil seal 2. Replace oil seal and stanchion tube 3. Clean the oil seal seat and replace it
Oil leaking through the bottom of slider	O-ring seal on the cartridge nut is damaged	Replace the O-ring seal
Fork has not been used for some time and is locked out	Oil seals and dust seals tend to stick to stanchion tube	Raise dust seal and lubricate stanchion tube, oil seal and dust seal
Fork rebounds too fast even though the adjuster is on the max. damping position	Cartridge is faulty	Replace hydraulic cartridge
Excessive play of stanchions into the sliders	Main slider bushings are worn	Replace main slider bushings

## RECOMMENDATIONS FOR USE

MARZOCCHI forks are based on advanced technology, supported by year-long experience in the field of professional mountain biking. In order to achieve best results, we recommend to check and clean the area below the oil seal and the stanchion tube after each use and lubricate with silicone oil.

## INSTALLATION

Installing the MONSTER T fork on a bicycle is a very delicate operation that should be carried out with extreme care. A threadless steer tube is pre-installed on the fork from the factory. It will need to be cut to the required length for a proper fit. The installation should always be checked by one of our Technical Service Centers.

 **WARNING:** "A-Head Set" headset/steer tube mounting and adjustment must be carried out in compliance with the headset manufacturer's instructions. Improper installation may jeopardize the safety of the rider.

After any installation always check for the following:

- proper torque of bolts fastening stanchion tube onto lower crown and upper plate;
- proper torque of bolts fastening brake arch onto slider
- proper torque of bolts fastening axle to drop out

For recommended torque settings, see the table below:

Thread diameter	Tightening torque Nm
M4	4
M5	9
M6	11

## MOUNTING THE FORK ON THE FRAME

### FIG. A

Remove the upper plate (28) from steer tube and fork legs by loosening the 3 fastening screws (29).

FIG. A

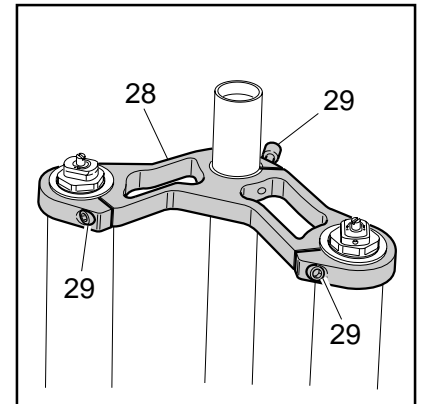

### FIG. B

Assemble the fork to the frame complete with headset. Fit the upper plate (28) into the upper stanchions and the steer tube.

FIG. B

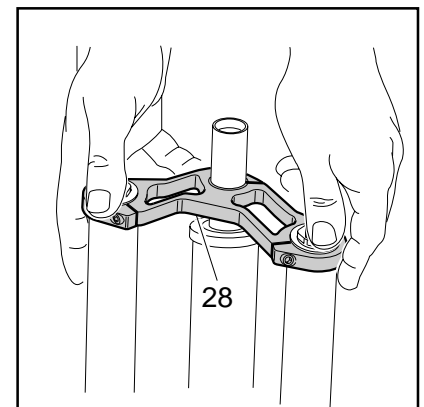

### FIG. C

The stanchions edge (13) must be aligned with or slightly lower than the upper plate (28).  
In case of frame with higher steer tube, use the plate supplied on request.

FIG. C

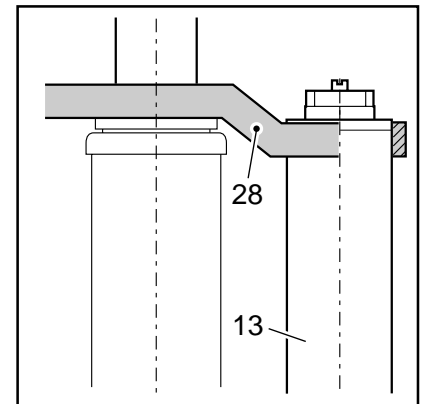

### FIG. D

Fit the handlebar support and the A-HeadSet plug over the upper plate (28) and then adjust the steering.  
Now finally tighten the 3 screws (29) on the upper plate.

FIG. D

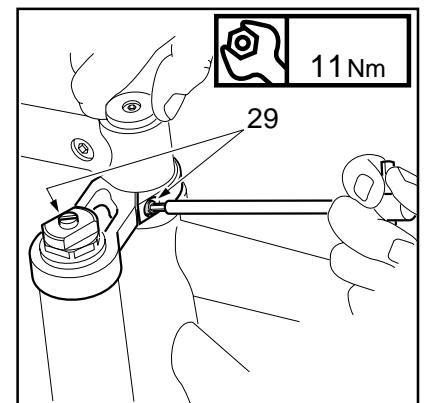

**⚠ IMPORTANT:** Loosen the 3 screws (29) on the upper plate before adjusting the steering. Tighten the above bolts at the required torque when finished.

**FIG. E**

If the crown (26) position with respect to the stanchion tubes (13) has been changed for any reason, adjust the original distance.

- Distance "H" between crown and tyre edge (when inflated) should not be lower than total travel (175 mm) + 3 mm.

**⚠ WARNING:** if steering crown is improperly matched with stanchions, it may touch the tyre and cause severe injuries to the rider.

**FIG. E**

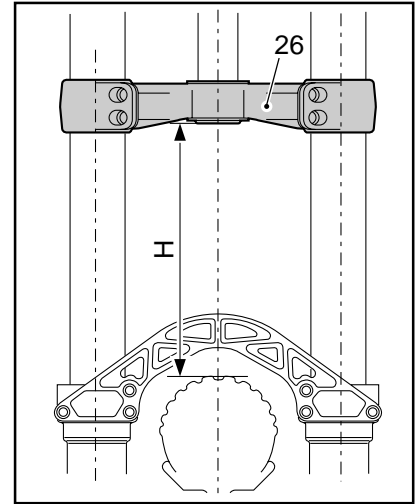
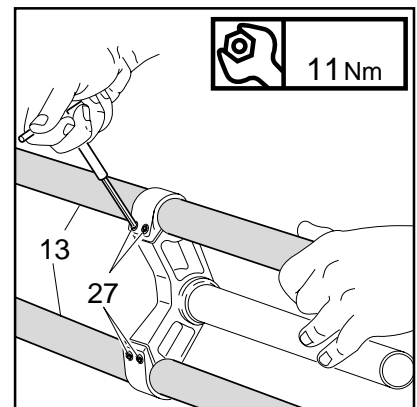

**FIG. F**

Tighten the 4 stanchions fastening screws (27) onto the crown at 11 Nm.

**⚠ WARNING:** do not overtighten the screws holding the stanchions to the crown as this may distort the stanchion tubes and weaken the whole structure.

**FIG. F**



## FRONT WHEEL FIXING

**⚠ IMPORTANT:** for a safe and proper performance of this fork and all related devices, the front wheel should be absolutely secured as specified in the instructions given below.

**FIG. G**

Insert the complete wheel between the sliders and the wheels axle (35) into the slider with the fastening bolt (23) from the right. Turn clockwise so that it rests against the left slider.

**FIG. G**

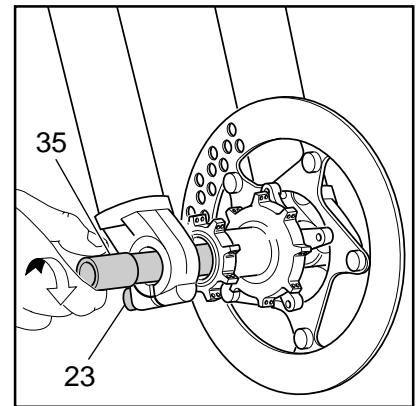

**FIG. H**

On the opposite side, screw the wheel axle (35) counter clockwise with a 8-mm Allen screw. Tighten at 20 Nm.

**FIG. H**

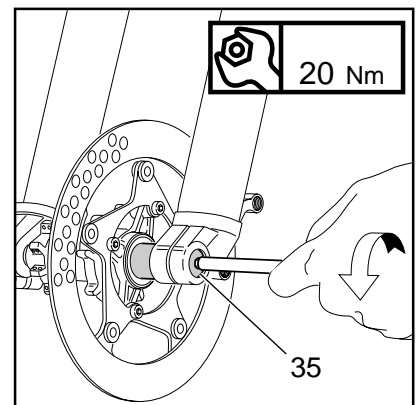

**FIG. L**

Compress the fork several times to adjust the sliders onto the wheel axle and then tighten the bolt (23) on the r.h. slider at 6 Nm.

**FIG. L**

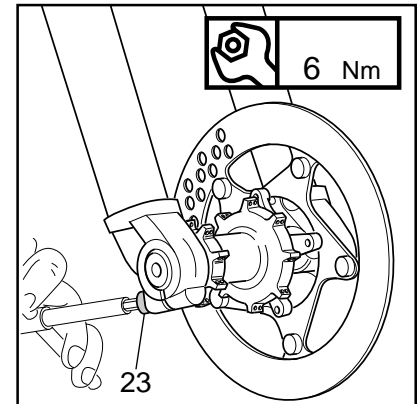

## DISASSEMBLY

To remove the wheel proceed as follows:

- loosen the bolt (23) on the r.h. drop-out (see FIG. L);
- screw the wheel axle (35) clockwise onto the l.h. drop-out (see FIG. H);
- remove the axle (35) from the opposite side.

## DISC BRAKE SYSTEM ASSEMBLY

Assembling the brake caliper onto the sleeve is a very delicate operation that should be carried out with extreme care. An improper assembly might overstress the caliper supports, which might break.

This system should be assembled by specialized technicians in a position to fully understand and properly follow the instructions given by the manufacturer.

## ADJUSTMENTS

**IMPORTANT:** both fork legs should be adjusted on the same position.

### SPRING PRELOAD (FIG. M)

The spring preload can be adjusted by turning the knob (2) on top of fork legs. From the factory the MONSTER T is set with the minimum preload, i.e. the adjustment knob is completely unscrewed counterclockwise. However, the springs are slightly preloaded to help counteract static loads. By turning the adjustment knob clockwise, the preload is increased up to the maximum value equal to 15 mm of spring preload. This adjustment is essential in order to have the right MONSTER T response for the rider weight and riding style.

**FIG. M**

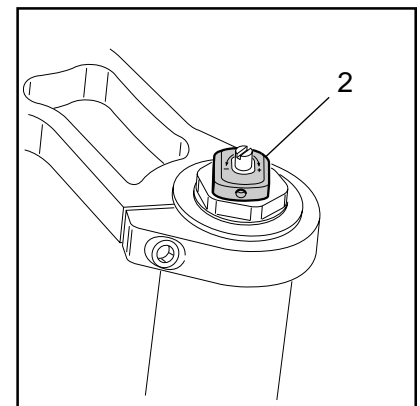

### REBOUND ADJUSTMENT (FIG. N)

Each fork leg is equipped with an adjustment screw (D) for damping during REBOUND. When turning this adjuster clockwise into the cartridge rod, hydraulic setting of the inner valves changes. In short, the amount of adjustment applied on the piston in the fluid determines the rate of compression & rebound damping.

To adjust, always start from the minimum damping setting, i.e. unscrew completely counterclockwise. About 8 turns - abt. 4 mm of the adjustment - are possible.

**FIG. N**

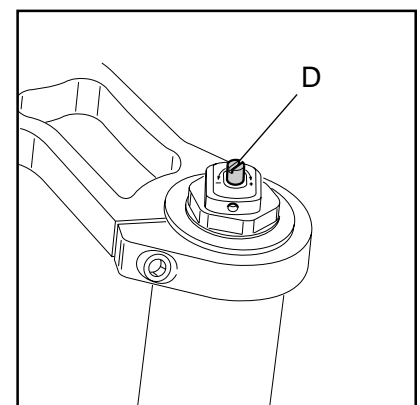

## DISASSEMBLY

### GENERAL

- The reference numbers given in this section relate to the components shown in the forks exploded view on page 16.
- These operations refer to the fork legs having already been removed from the crown and disassembled from the brake arch.
- Before starting any operation, please read the diagram below. It shows the quickest procedure and the exact sequence in which it should be disassembled. Start from the part first to be disassembled and then follow the arrows to remove the remaining parts.

### DISASSEMBLY DIAGRAM

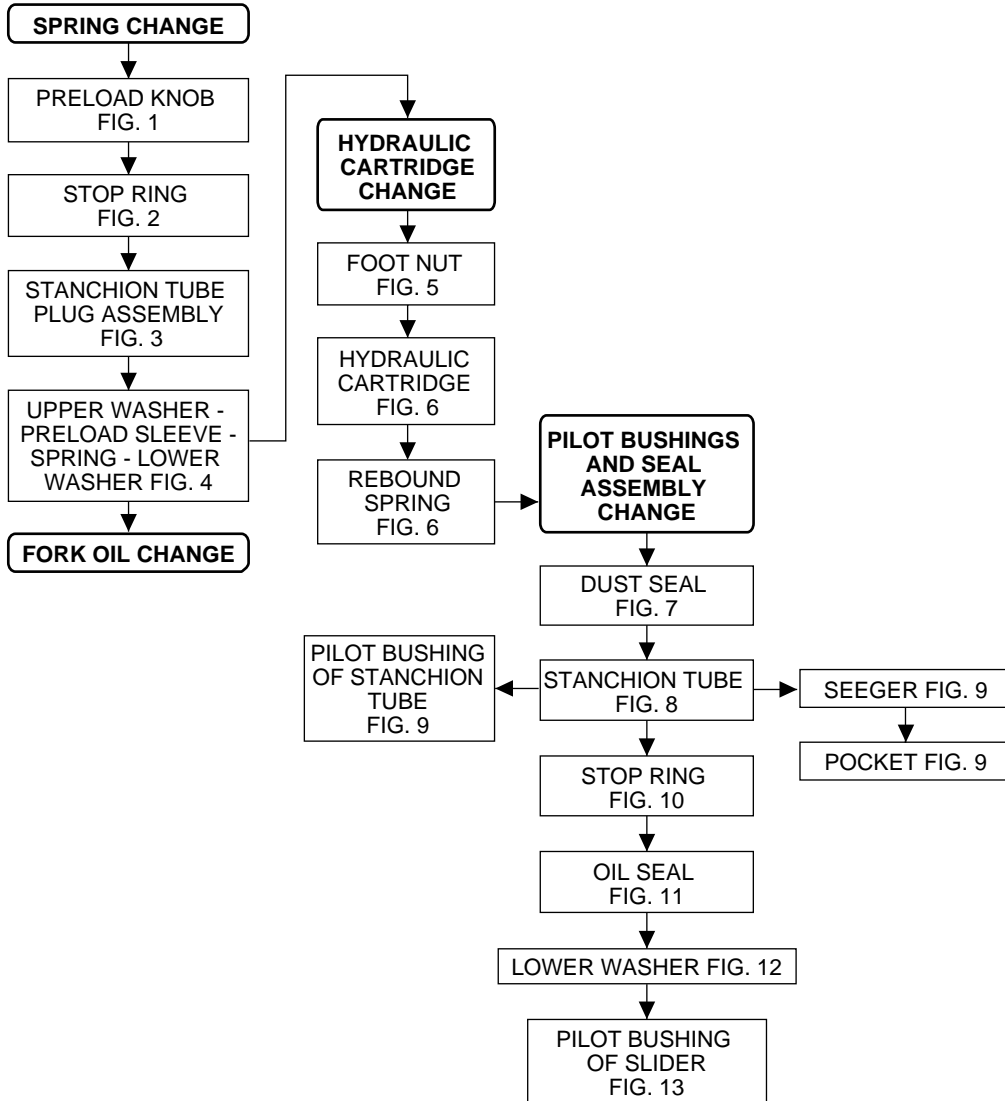

### SPRING CHANGE FIG. 1

Position the knob (2) to the minimum preload value. Loosen the small Allen bolt (3) fastening the preload knob (2) by means of a 1.5 mm Allen wrench. Remove it from the plug assembly.

FIG. 1

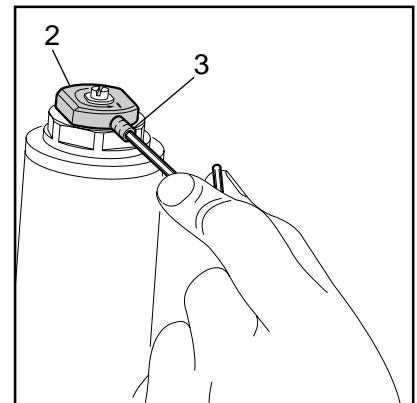
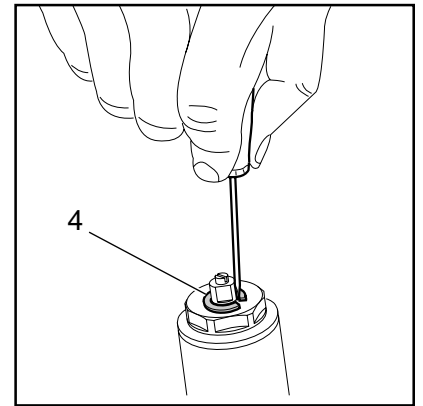



**FIG. 2**

Remove the stop ring (4) from the top of the preload knob support with a small screwdriver.

**FIG. 2**



**FIG. 3**

Hold the stanchion tube making sure not to damage it and unscrew the plug (5) with a 26 mm End wrench. Remove the plug complete with O-ring (6) intact from the stanchion tube.

**FIG. 3**

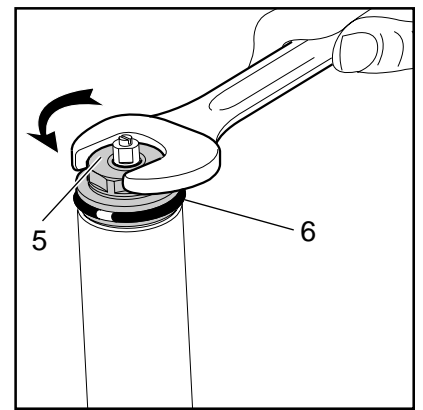

**FIG. 4**

Push the stanchion tube into the slider and remove the upper washer (8), the preload sleeve (1) and the spring (9). Let all the oil drain into the fork leg. By following this procedure, there is no need to check the oil level. Make all necessary changes.

**FIG. 4**

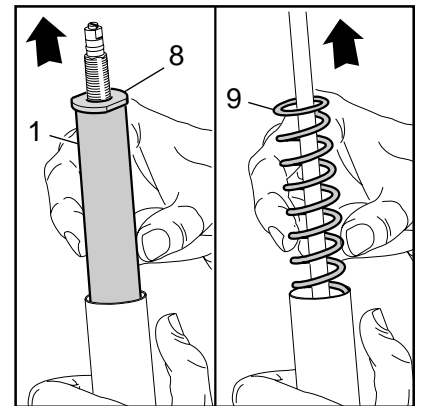

## HYDRAULIC CARTRIDGE CHANGE

**FIG. 5**

Let all the oil drain out.

**FIG. 5**

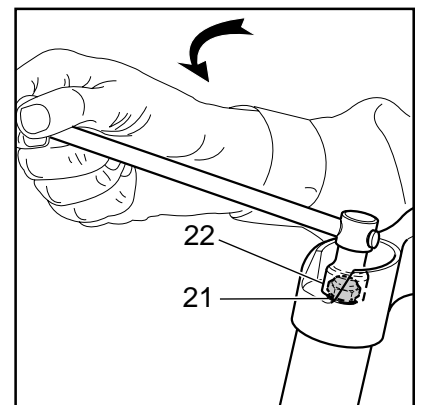

**WARNING:** Remember to always recycle any used oil.

To change the fork leg oil follow the procedure as described in the REASSEMBLY from FIG. 23 to FIG.28.

Turn the fork leg upside-down and unscrew the foot nut (22) complete with O-ring (21) by the use of a 15 mm socket wrench.

**FIG. 6**

Pull the hydraulic cartridge (11) complete with lower washer (8A) and rebound spring (12) out of the stanchion tube. Replace the whole hydraulic cartridge.

**FIG. 6**

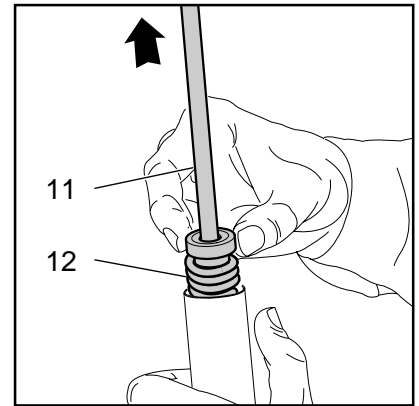

## PILOT BUSHINGS AND SEAL ASSEMBLY CHANGE

**FIG. 7**

Use a small screwdriver and remove the dust seal (14) from the slider top.

**FIG. 7**

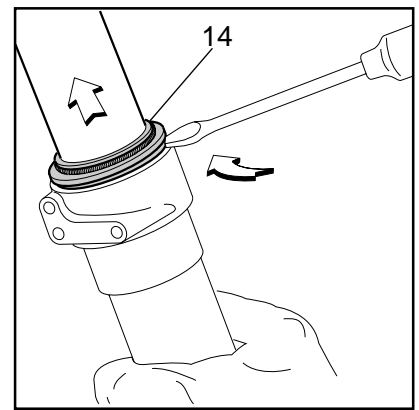

**FIG. 8**

Pull the stanchion tube (13) completely out of the slider. Pull strongly to win the resistance of the pilot bushing (34) of the stanchion tube to cross the slider bushing (18).

**FIG. 8**

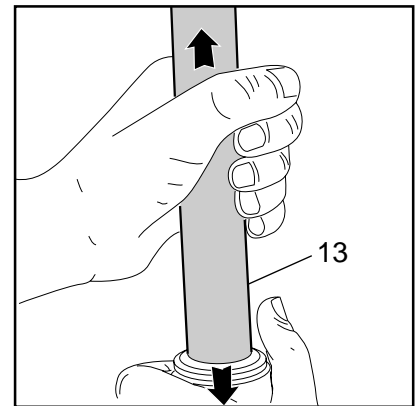

**⚠ IMPORTANT:** the seal unit will be permanently damaged by the pilot bushing (34).

Always change the seal rings after the above procedure.

**FIG. 9**

A pocket (33) is inside the stanchion tube. Remove the outer snap ring (32) to remove the pocket (33). Should the pilot bushing (34) be damaged, remove it from the stanchion (13) inserting a small screwdriver into the bushing slot.

**FIG. 9**

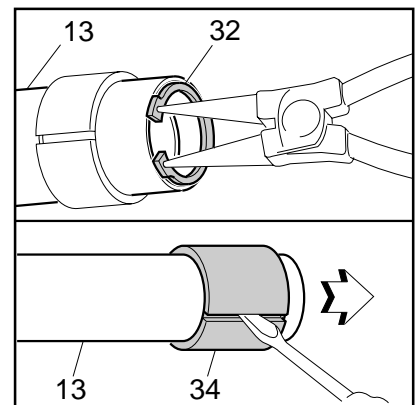
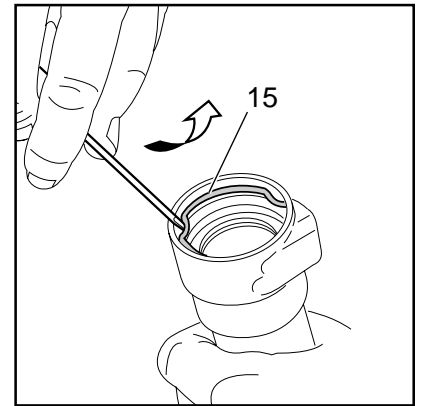

**FIG. 10**

Remove the stop ring (15) from the slider by placing the screwdriver bit in one of the openings on the stop ring and carefully lifting the ring out of place.

**⚠ IMPORTANT:** when removing the stop ring, make sure not to damage its seat.

**FIG. 10**

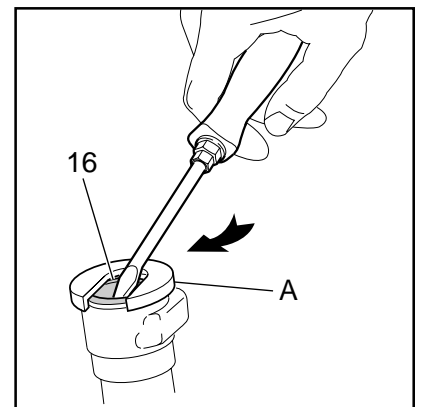

**FIG. 11**

Fit the slider protection tool (A) onto the slider and remove the oil seal (16) with the help of a large slot screwdriver.

**⚠ IMPORTANT:** when removing the oil seal, make sure not to damage its seat. Once removed, the oil seals should not be used again.

**FIG. 11**



**FIG. 12**

Remove the upper washer (17) from the slider.

**FIG. 12**

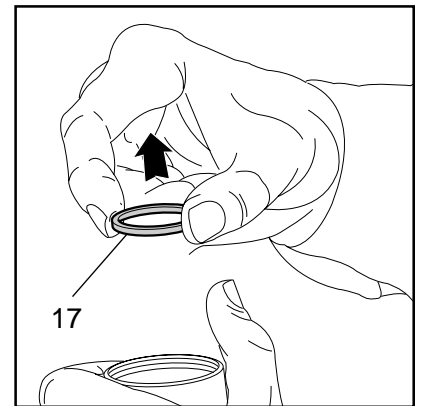

**FIG. 13**

To remove the pilot bushing (18), beat powerfully the slider edge on a wooden surface. Perform this operation with extreme care and try to keep the slider perpendicular to the wooden surface.

**FIG. 13**

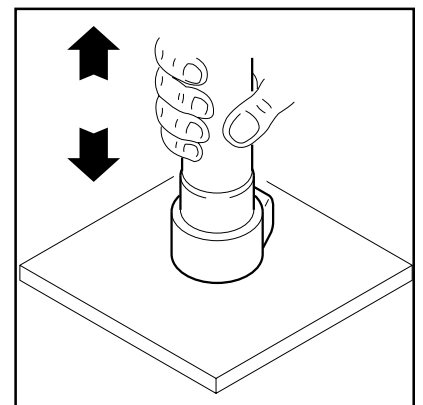

## REASSEMBLY

**CAUTION:** before reassembling, all metal components should be washed carefully with inflammable and biodegradable solvent and dried with compressed air.

**FIG. 14**

Fit the pocket (33), with its completely open side facing outwards, on the stanchion edge (13). Fit the outer snap ring (32). Make sure it is fully seated in the tube.

**FIG. 14**

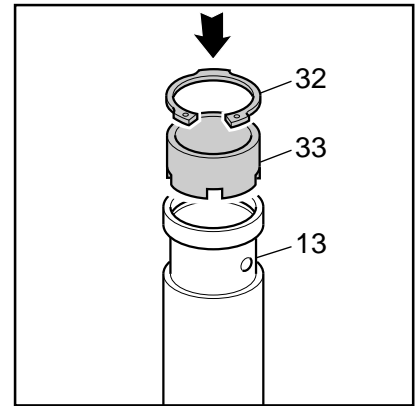

**FIG. 15**

Stick some adhesive tape onto the stanchion bottom (13) to protect it. Insert the oil seal (16), duly lubricated, the bushing washer (17) and the slider pilot bushing (18) into the stanchion. Remove the adhesive tape and clean the stanchion.

**FIG. 15**

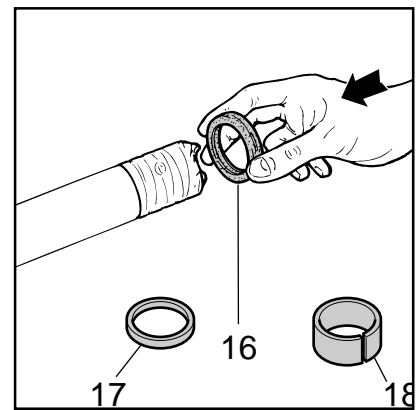

**FIG. 16**

Insert the bit of the flat screwdriver into the pilot bushing guide slot (34) to fit it on the stanchion tube. Put it into the tube seat by hand.

**FIG. 16**

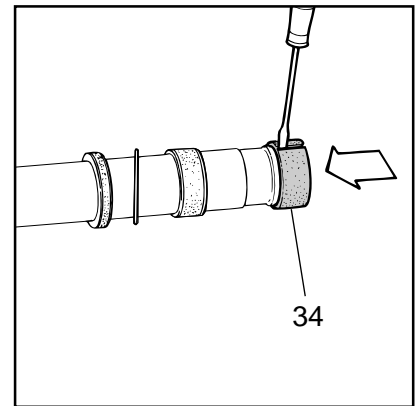

**FIG. 17**

Gently insert the stanchion tube (13) into the slider from the bushing side. Fit the pilot bushing (18) and the bushing washer (17) into the slider seat by hand.

**FIG. 17**

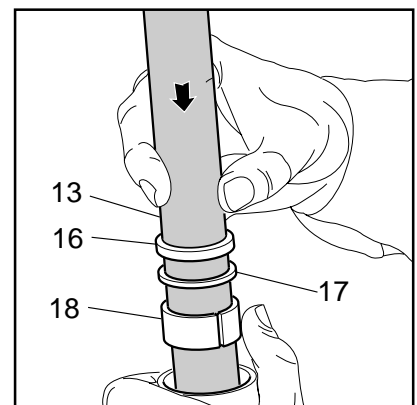

**FIG. 18**

Press the oil seal (16) into place until it touches the lower washer (17) by using the seal press (B).

**FIG. 18**

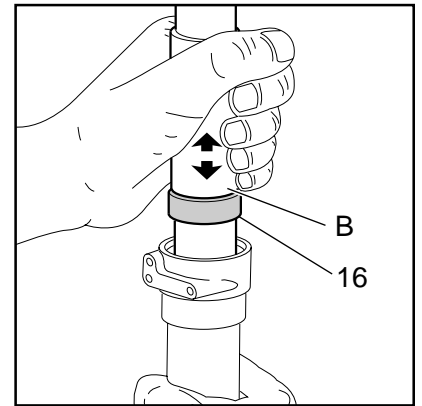

**FIG. 19**

Insert the stop ring (15) making sure it is properly seated into place.

**FIG. 19**

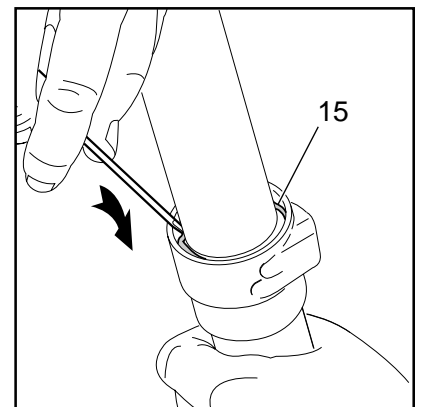

**FIG. 20**

Lubricate the dust seal (14) and insert it into the top of the slider. Fit it into the slider seat.

**FIG. 20**

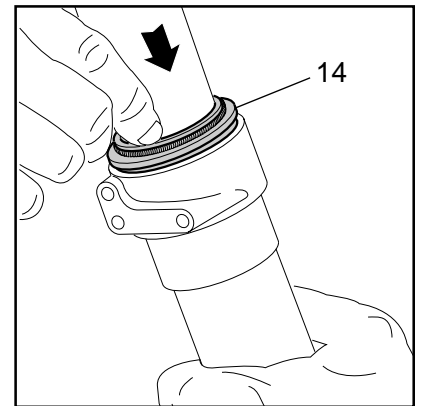

## HYDRAULIC CARTRIDGE

**FIG. 21**

Fit the rebound spring (12) into the hydraulic cartridge. Insert the complete hydraulic cartridge (11) by compressing the stanchion tube completely to the bottom of its stroke.

**FIG. 21**

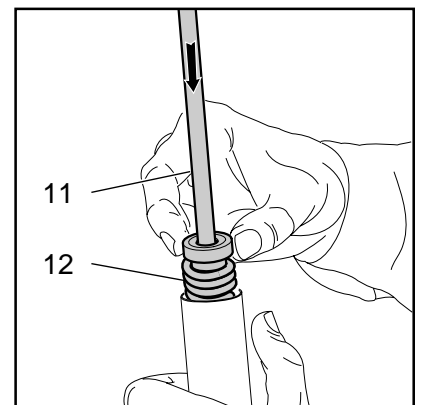

**FIG. 22**

Grease the O-ring (21) on the foot nut (22) and screw the nut on the hydraulic cartridge threaded end.  
Tighten at 12 Nm.  
Check to verify that the stanchion tube slides properly through the stroke by pumping it up and down several times.

**FIG. 22**

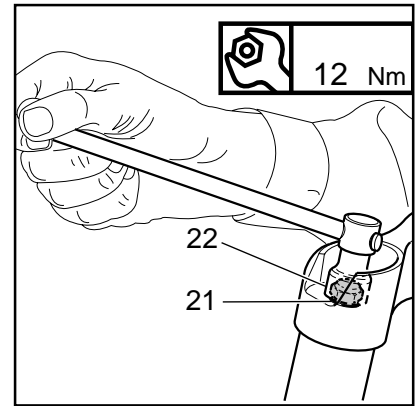

## HOW TO FILL WITH OIL

**FIG. 23**

Pour the oil little by little when the stanchion tube is fully down and then pump with the cartridge (11) rod so as to have a better filling. Cartridge is full when no air is detected when pumping, in the completely closed position. Check that the oil level is 100mm from the top of the stanchion tube.

**FIG. 23**

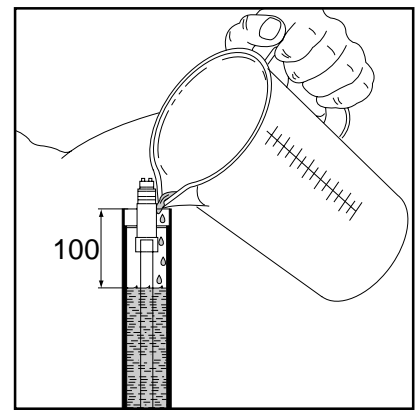

## SPRING AND PLUG

**FIG. 24**

Fit the lower washer (8A), the spring (9), the preload sleeve (1) and the upper washer (8) into the stanchion tube.  
Lubricate the O-ring (10) on the top of the preload knob support and the O-ring (6) on the plug (5).

**FIG. 24**

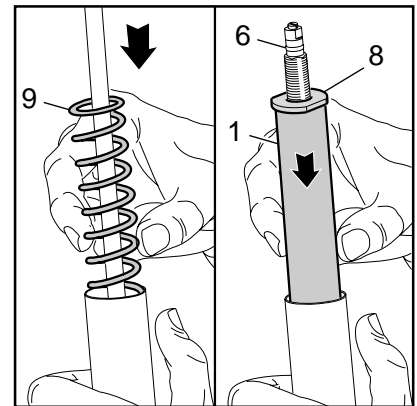

**FIG. 25**

Position the preload adjuster (7), into the plug, to the minimum preload value.  
Screw the complete plug (5) onto the cartridge (11) rod to the bottom of its stroke.

**FIG. 25**

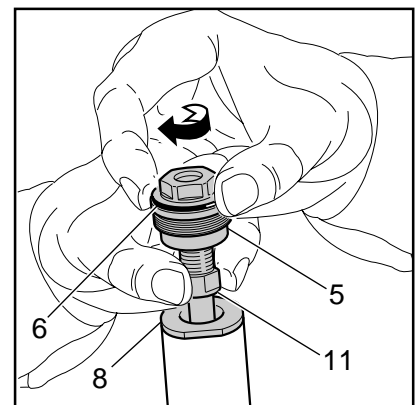

**FIG. 26**

Lift the stanchion tube and fit the plug (5) by hand. Fix the stanchion tube in vice. Make sure not to damage or squeeze it. Tighten at 12 Nm.

**FIG. 26**

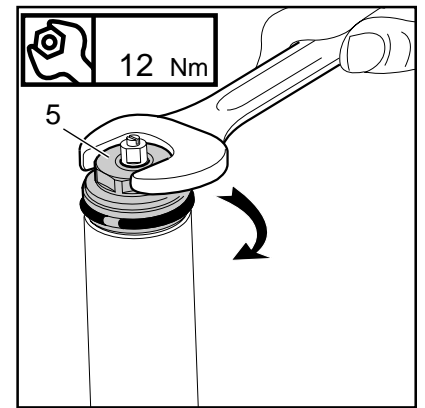

**FIG. 27**

Fit the stop ring (4) of the preload knob support and make sure it is fitted properly into its seat.

**FIG. 27**

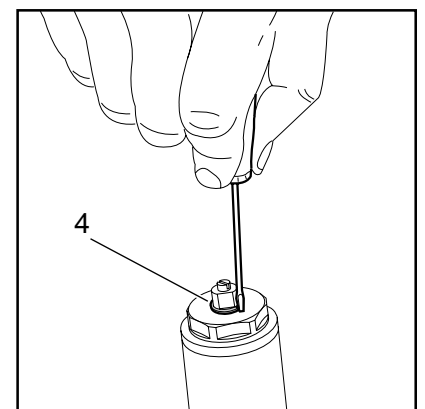
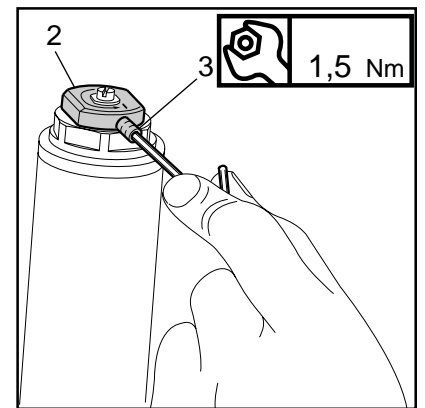

**FIG. 28**

Fit the preload knob (2), secure it on the support and tighten the Allen bolt (3) at 1.5 Nm

At this point, the brake arch can be assembled with the fork legs, which should be fitted onto the crown and onto the upper plate as specified in the chapter "INSTALLATION".

**FIG. 28**



## FORK EXPLODED VIEW

**Ref. Description**

- 1 Preload sleeve
- 2 Preload knob
- 3 Allen bolt
- 4 Stop ring
- 5 Plug
- 6 O-ring
- 7 Preload adjuster
- 8 Upper washer
- 8A Lower washer
- 9 Spring
- 10 O-ring
- 11 Hydraulic cartridge
- 12 Rebound stop spring
- 13 Stanchion tube
- 14 Dust seal
- 15 Stop ring
- 16 Oil seal
- 17 Upper washer
- 18 Slider pilot bushing
- 19 R.H. slider
- 20 L.H. slider
- 21 O-ring
- 22 Foot nut
- 23 Screw
- 24 Arch
- 25 Screw
- 26 Crown and steer tube
- 27 Screw
- 28 Upper plate
- 29 Screw
- 30 L.H. sticker
- 31 R.H. sticker
- 32 Snap ring
- 33 Pocket
- 34 Pilot bushing of the stanchion tube
- 35 Wheel axle

